

Humanoid Robot Joints Product Solutions

人形机器人关节产品解决方案



 **JOHNSON
ELECTRIC**

人形机器人关节模组产品 Humanoid Robot Joints Product Solutions

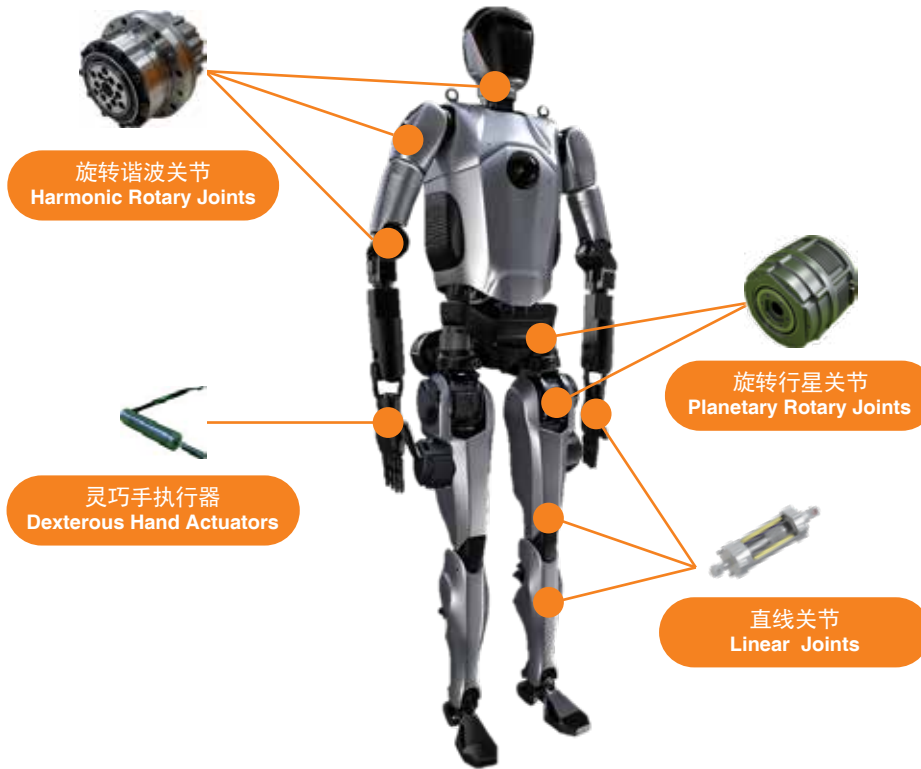

2023年开始开发机器人关节，目前产品覆盖人形机器人上所有类型的关节模组，包括旋转、直线关节和空心杯电机灵巧手执行器，全部正向开发并且综合自制率高达90%

Started development of robotics joints from 2023 and platform covers all types of joint modules on humanoid robots, including rotary, linear joints and dexterous hand actuators with inhouse rate over 90%

产品特点 Product Features

高扭矩密度：紧凑尺寸，强劲输出
High Torque Density: Compact design with powerful output

低背隙高精度：实现人类般柔顺动作
Low Backlash & High Precision: Ideal for smooth, human - like movement

高度集成模块化：电机、减速器、编码器、刹车（可选）一体化
Modular Integration: Motor, gear, encoder and brake (Optional) all in one

静音高效：优化低噪音与高能效输出
Quiet & Efficient: Optimized for low - noise, high - efficiency actuation

高可靠长寿命：设计寿命超过一万小时
Reliable & Durable: 10,000 + hrs of continuous use with advance thermal management

AI友好型设计：兼容EtherCAT，CAN等工业协议
Ready for AI Control: Compatible with EtherCAT, CAN

旋转关节是人形机器人的核心动力单元
The rotary joint is the core power unit of the humanoid robot.

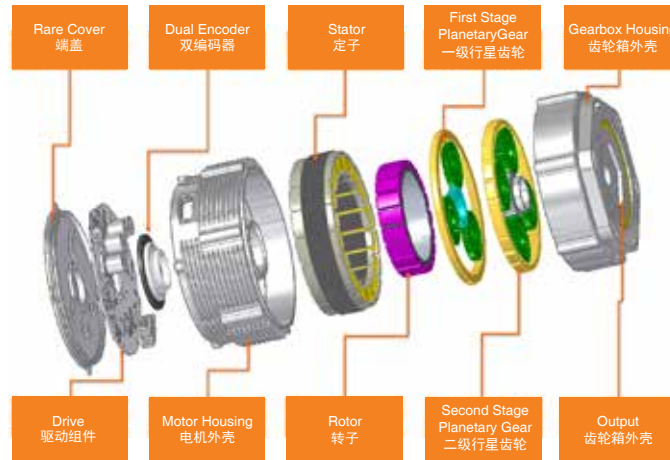







旋转关节-行星减速器 Rotary Joints - Planetary

Specifications 产品参数	R-120/396-P-18	R-90/192-P-16	R-80/120-P-12	R-70/104-P-32
Picture 图片				
Voltage 电压 VDC	48	48	48	48
Rated Torque 额定扭矩 Nm	90	40	40	40
Peak Torque 峰值扭矩 Nm	396	192	120	104
Rated Speed 额定速度 RPM	127	100	100	75
ODxL 尺寸 mm	Φ132x99	Φ100x82	Φ88x80	Φ78x78.6
Hollow OD 中空直径 mm	Φ17	Φ16	Φ16	-
Weight 重量 Kg	2.85	1.50	1.20	0.97
Encoder 编码器	19/20, Abs.	19/20, Abs.	19/20, Abs.	18/19, Abs.
Communication 通信协议	EtherCat/CAN	EtherCat/CAN	EtherCat/CAN	EtherCat/CAN
Reducer 减速器	Planetary 行星减速器	Planetary 行星减速器	Planetary 行星减速器	Planetary 行星减速器











旋转关节-谐波减速器 Rotary Joints - Harmonic

定制化谐波减速器
Customized harmonic gearbox

Specifications 产品参数	R-120/433-H-100 (Harmonic 32) 参考谐波型号32	R-90/204-H-100 (Harmonic 25) 参考谐波型号25	R-80/107-H-100 (Harmonic 20) 参考谐波型号20	R-70/70-H-100 (Harmonic 17) 参考谐波型号17	R-50/36-H-100 (Harmonic 14) 参考谐波型号14	R-38/7.7-H-100 (Harmonic 11) 参考谐波型号11	R-30/3.3-H-100 (Harmonic 08) 参考谐波型号08
Picture 图片							
Voltage 电压 vdc	48	48	48	48	48	48	48
Ratio 速比	100	100	100	100	100	100	100
Rated Torque 额定扭矩 Nm	178	87	52	31	10 (30)*	3.5 (5)*	1.65
Start/Stop Torque 启/停 扭矩 Nm	433	204	107	70	36 (66)*	7.7 (11)*	3.3
Lim. for Ave. Torque 最大平均负载 Nm	281	140	64	51	14 (49)*	6.2 (8.9)*	2.3
Emergency Torque 紧急扭矩 Nm	841	369	191	143	70 (134)*	17.5 (25)*	6.3
Max. Input Speed 最大输入速度 RPM	3611	3616	3636	3086	4807	5604	8000
Rated output Speed 额定输出速度 RPM	22	22	22	20	20	30	20
Backlash 背隙 Arcsec	≤20	≤20	≤20	≤20	≤20	≤30	≤40
ODxL 尺寸ODxL mm	Φ142x100	Φ110x92	Φ90x85	Φ80x81	Φ70x70	Φ52x60	Φ40x60
Hollow OD 中空直径 mm	32	16	16	Φ12	Φ12	Φ9	Φ3
Weight 重量 Kg	5.2	2.5	1.75	1.10	0.88	0.33	0.20
Encoder 编码器	18/19, Abs.	19/20, Abs.	19/20, Abs.	18/19, Abs.	18/19, Abs.	24/24, Abs.	24/24, Abs.
Communication 通信协议	EtherCat/CAN						
Brake 刹车	Yes/No	Yes/No	Yes/No	No	No	No	No



无框力矩电机-旋转关节马达 Frameless Torque Motors – Rotary Joints

Specifications 产品参数	JETM-11618	JETM-11613	JETM-08913	JETM-08911	JETM-07607	JETM-06816	JETM-06810	JETM-06010	JETM-05012	JETM-03805	JETM-03005
Picture 图片											
Rated Voltage 额定电压 [VDC]	48	48	48	48	48	48	48	48	48	48	48
Rated Current 额定扭矩电流 [A]	30.5	23.0	14.1	7.2	3.3	11.9	9.5	5.0	3.8	1.0	0.4
Rated Torque 额定扭矩 [Nm]	5.38	3.59	3.03	1.82	0.82	1.41	0.94	0.69	0.37	0.09	0.04
Rated Speed 额定转速 [RPM]	2300	2900	1600	1600	1600	2400	2400	2900	3500	3500	2000
Peak Current 峰值扭矩电流 [A]	155.0	132	78.5	22.6	9.2	30.6	58.8	8.3	9.9	1.8	1.1
Peak Torque 峰值扭矩 [Nm]	25.44	19.36	14.09	5.78	2.37	3.6	4.88	1.18	0.83	0.17	0.10
Speed@ Peak Torque 峰值扭矩转速 [RPM]	350	350	300	300	300	300	300	1500	300	1000	600
Rated power 额定功率 [W]	1317	1100	508	305	137	354	336	210	135	33	8.5
Weight 重量 [g]	915	828	420	382	183	288	227	155	120	41	26
Dimension 尺寸 [mm]	Ø116X34.0	Ø116X29.7	Ø89X26.9	Ø89X24.5	Ø76X20.8	Ø68X30.0	Ø68X22.8	Ø60X19.4	Ø50X20.5	Ø38X13.9	Ø30X13.3



直线关节是人形机器人的核心部件，可实现精准、大扭矩且可控的直线运动
Linear joints are the core components of humanoid robots that enable precise, powerful and controllable linear motion.

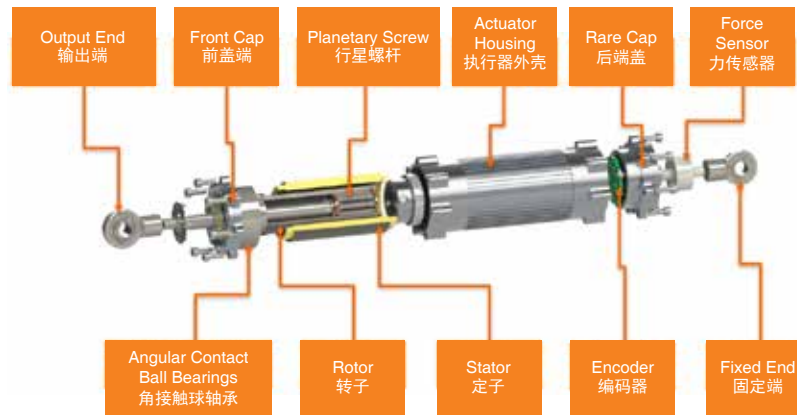

直线关节 Linear Joints

Specifications 产品参数	L-30/650-PRS-3	L-40/4000-PRS-3	L-60/8500-PRS-5	L-40/5000-BS-3	L-60/10000-BS-5
Picture 图片					
Rated Voltage 额定电压 VDC	48	48	48	48	48
Rated Force 额定推力 N	325	1800	4000	2000	4000
Peak Speed 峰值速度 mm/s	300	400	600	400	600
Peak Force 峰值推力 N	650	4000	8500	5000	10000
Effective Stroke 有效行程 mm	50	75	100	90	110
Weight 重量 Kg	0.5	1.5	2.9	1.6	2.9
Dimension 尺寸 mm	Φ50x125	Φ70x236	Φ75x265	Φ61x236	Φ81x265
Reducer Type 减速器类型	Planetary Roller Screw 行星滚柱丝杠 PRS	Planetary Roller Screw 行星滚柱丝杠 PRS	Planetary Roller Screw 行星滚柱丝杠 PRS	Ball Screw 滚珠丝杠 BS	Ball Screw 滚珠丝杠 BS

无框力矩电机-直线关节马达 Frameless Torque Motor - Linear Joints

Specifications 产品参数	JETM-04370	JETM-06480
Picture 图片		
Rated Voltage 额定电压 VDC	48	48
Rated Current 额定扭矩电流 A-rms	19.8	80.0
Rated Torque 额定扭矩 Nm	1.36	4.50
Rated Speed 额定转速 RPM	8140	7200
Peak Current 峰值扭矩电 A-rms	48.3	148.8
Peak Torque 峰值扭矩 Nm	2.73	9.66
Speed@ Peak Torque 峰值扭矩转速 RPM	6990	6000
Rated power 额定功率 W	1158	3347
Weight 重量 g	369	1052
Dimension 尺寸 mm	Ø43X77.5	Ø64X90.2



手部执行器是人形机器人实现精细动作的核心部件



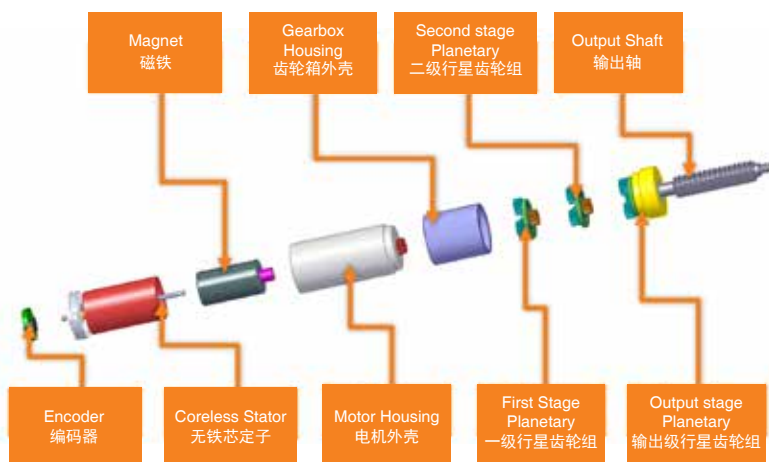

Hand actuators are key components in humanoid robots for achieving precise movements.











灵巧手执行器-旋转输出 Dexterous Hand Actuators - Rotary Output

Specifications 产品参数	HB-10/0.08-P-51	HB-10/0.17-P-111	HB-12/0.22-P-70	HBL-12/1-P-70	HBL-16/1-P/Bg-194/1
Picture 图片					
Motor Type 马达类型	Coreless DC 空心杯电机	Coreless DC 空心杯电机	Coreless DC 空心杯电机	Coreless BLDC 空心杯电机	Slotted BLDC 齿槽电机
Voltage 电压 VDC	12	12	12	12	24
Gearbox Ratio 减速比	51	111	70	70	194
Rated Torque 额定扭矩 mNm	40	40	30	40	500
Rated Speed 额定速度 RPM	180	120	180	400	80
Peak torque 峰值扭矩 mNm	80	170	220	1000	1000
ODxL 尺寸 mm	10x41	10x41	12x50	12x50	16x42
Weight 重量 g	16	16	30	35	/
Encoder 编码器	256线增量式	256线增量式	256线增量式	256线增量式	多圈绝对式

灵巧手执行器-直线输出 Dexterous Hand Actuators - Linear Output

Specifications 产品参数	HBL-8/140-P/L-69/1	HBL-10/130-P/L-23/1	HBL-12/100-P/L-4/1	HBL-16/200-P/Bs-5/1
Picture 图片				
Motor Type 马达类型	Coreless BLDC 马达类型	Coreless BLDC 马达类型	Coreless BLDC 马达类型	Slotted BLDC 马达类型
Voltage 电压 VDC	12	12	12	24
Gearbox Ratio 减速比	69	23	4	5
Screw Type 丝杠类型	Lead screw	Lead screw	Lead screw	Ball screw
Screw Lead 丝杠导程 mm	1	1	1	1
Travel 行程 mm	15	16	25	30
Rated Force 额定输出力 N	80	80	75	120
Rated Speed 额定速度 mm/s	5	8	20	50
Peak Force 峰值输出力 N	140	130	100	200
ODxL 尺寸 mm	8x31	10x61	12x75	16x90
Weight 重量 g	/	/	/	70
Encoder 编码器	256 Incremental 256线增量式	256 Incremental 256线增量式	256 Incremental 256线增量式	15 bit abs. 15位绝对式

灵巧手执行器马达 Dexterous Hand Motors

Specifications 产品参数	Coreless Brushed Motor 空心杯DC OD 6mm	Coreless Brushed Motor 空心杯DC OD 8mm	Coreless Brushed Motor 空心杯DC OD 10mm	Coreless Brushed Motor 空心杯DC OD 12mm	Coreless BLDC Motor 空心杯BLDC OD 8mm	Coreless BLDC Motor 空心杯BLDC OD 10mm	Coreless BLDC Motor 空心杯BLDC OD 12mm	Slotted BLDC Motor 齿槽BLDC OD 12mm	Slotted BLDC Motor 齿槽BLDC OD 16mm
Picture 图片									
Rated Voltage 额定电压 [VDC]	6	6	12	12	12	12	12	12	24
Free Load Current 空载电流 [A]	0.073	0.042	0.015	0.013	0.07	0.069	0.137	0.40	0.200
Free Load Speed 空载转速 [RPM]	59717	25982	16986	14908	35191	34330	43858	44000	22300
Rated Torque 额定扭矩 [m-Nm]	0.2	0.4	1.0	1.5	0.5	1.9	3.0	3.0	5.1
Rated Current 额定电流 [A]	0.295	0.230	0.169	0.211	0.229	0.542	1.3	1.3	0.73
Rated Speed 额定转速 [RPM]	47702	21929	11082	11170	27607	24962	39583	40000	20000
Stall Current 堵转电流 [A]	1.177	1.245	0.456	0.804	0.81	1.804	12.07	21.24	6.0
Stall Torque 堵转扭矩 [m-Nm]	0.994	2.564	2.877	5.982	2.32	6.963	30.78	62.07	57.4
Weight 重量 [g]	1.8	4.2	6.4	11.5	/	9.1	14.2	13.2	27.4
Dimension 尺寸 [mm]	Ø6 X 15.3	Ø8 X 19	Ø10 X 17.5	Ø12 X 24.1	Ø8 X 15.7	Ø10 X 23	Ø12 X 25	Ø12 X 25	Ø16 X 32.8

